

Direct Operated Type Solenoid Operated Proportional Directional Control Valve

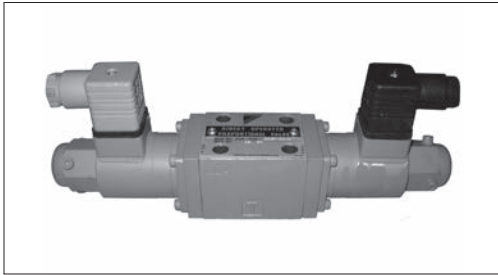

Features

- These four-way proportional directional control valves enable control of the forward and reverse motion of an actuator.
- The valve can be used alone as a shockless directional control valve.

- With differential transformer
 - These proportional directional control valves perform spool position feedback control by directly driving the spool with the proportional solenoid and detecting the displacement with the differential transformer.
 - Combining the valve with a pressure compensation valve and the dedicated driver achieves highly accurate proportional flow rate control.
- Without differential transformer
 - Installed with the dedicated driver (ZDN-2-10).
 - The valve can be used as a simple flow control valve by combining it with a pressure compensation valve.

Nomenclature

● **Nominal diameter 02**

KSP - G 02 - *** * * - **10** - * - ***

1
2
3
4
5
6
7
8
9

● **Nominal diameter 03**

KSP - G 03 - *** * - **10** - ***

1
2
3
4
5
7
9

1 Model No.
(Applicable fluids: petroleum-based hydraulic oil)
 KSP: Solenoid operated proportional directional control valve

2 Connections
 G: Gasket mount type

3 Nominal diameter
 02: ¼
 03: ⅜

4 Spool type and spool operating method (See the spool type table)

5 Rated flow rate (the values at 1 land differential pressure: ΔP = 1 MPa {10 kgf/cm²})
 1: 10 L/min (Applicable only to KSP-GO2)
 2: 18 L/min (Applicable only to KSP-GO2)
 3: 30 L/min (Applicable only to KSP-GO2 equipped with differential transformer (option code M))
 4: 40 L/min (Applicable only to KSP-GO3)
 5: 50 L/min (Applicable only to KSP-GO3)

6 Solenoid code *1
 P: DC 24 V solenoid
 N: DC 12 V solenoid

7 Design No.
(The design No. is subject to change)

8 Option code *2
 No designation: Without differential transformer, with driver ZDN-2-10
 N: Without differential transformer, without driver ZDN-2-10
 M: With differential transformer
 Note: Models with a differential transformer or with a driver are not available with nominal diameter 03 (⅜).

9 Auxiliary spool type (See the spool type table)

Note: *1 The solenoid code applies only to option code N.
 *2 The option code applies only to nominal diameter 02 (¼)

Specifications

| Model code | Nominal diameter | Maximum operating pressure MPa {kgf/cm ² } | Rated flow rate *3 L/min | Permissible back pressure MPa {kgf/cm ² } | Hysteresis, resolution, repeatability | Mass kg | |
|--------------------|------------------|--|-----------------------------|---|---------------------------------------|-----------------|-----------------|
| | | | | | | Double solenoid | Single solenoid |
| KSP-G02-***1*-10 | ¼ | 35 {350} | 10 | 2.5 { 25} | 5% maximum | 2.7 | 2.1 |
| KSP-G02-***2*-10 | | | 18 | | | | |
| KSP-G02-***1*-10-M | | | 10 | | 1% maximum | 3.1 | 2.5 |
| KSP-G02-***2*-10-M | | | 18 | | | | |
| KSP-G02-***3*-10-M | | | 30 | | | | |
| KSP-G03-***4*-10 | ⅜ | | 40 | 16 {160} | 8% maximum | 6.5 | 4.8 |
| KSP-G03-***5*-10 | | | 50 | | | | |

Note: *3 The rated flow rate indicates the value at 1 land differential pressure: ΔP = 1 MPa {10 kgf/cm²}.

Applicable driver model code

| Valve model code | Solenoid Code | Solenoid | Maximum current (20°C) mA | Coil resistance (20°C) Ω | Applicable driver | |
|------------------------|---------------|----------|---------------------------|--------------------------|-------------------|---|
| | | | | | Model code | Power supply voltage |
| KSP-G02-***-10 | — | DC 12 V | 1400 | 6.5 | ZDN-2-10 | DC 24 V |
| KSP-G02-***C*N-10-N | N | | | | EPD-03-10 | |
| KSP-G02-***A(B)*N-10-N | | | | | EPK-02-10 | |
| KSP-G02-***C*P-10-N | P | DC 24 V | 700 | 26 | KC-6-10 | AC 100, 200, 220 V (Common for 50 and 60 Hz) |
| KSP-G02-***A(B)*P-10-N | | | | | | |
| KSP-G02-***C*-10-M | — | DC 12 V | 1600 | 6.5 | EPKD-02-10 | DC 24 V |
| KSP-G02-***A(B)*-10-M | | | | | EPKF-02-10 | |
| KSP-G03-***C*-10 | | | 1800 | 4.2 | EPD-03-10 | |
| KSP-G03-***A(B)*-10 | | | | | EPK-03-10 | |

4 9: Spool type table

| Spool type and spool operating method | JIS graphic symbols for hydraulic system | Spool type and spool operating method | JIS graphic symbols for hydraulic system | Spool type and spool operating method | JIS graphic symbols for hydraulic system |
|---------------------------------------|--|---------------------------------------|--|---------------------------------------|--|
| 2C | | 2A...H2 | | 81A...H44 | |
| 44C | | 2B...2T | | 8B...44T | |

Note: The model code after ... indicates the model of the auxiliary spool.

Sub-plate model code

- The sub-plate is not provided with the valve. Order it separately as required by specifying the model code given in the table below.

| Model code | Nominal diameter | Connection port diameter | Mass kg |
|------------|------------------|--------------------------|---------|
| JS-01M02 | 1/4 | Rc1/4 | 0.64 |
| JS-02M03 | | Rc3/8 | 2.3 |
| JS-03M | 3/8 | Rc3/8 | 2.5 |
| JS-03M04 | | Rc1/2 | 2.2 |

Refer to Page S-9 for the dimensions of the sub-plate.

Handling

- Directly connect the tank piping of the valve to the tank without merging it with other tank piping.
- The input voltage - flow rate characteristics of these valves vary from valve to valve. Even when using valves of the same model, the flow rates of individual valves have to be finely adjusted. The degree of variation can be corrected by adjusting the maximum and minimum values with the dedicated driver's MAX/MIN trimmer.
- Do not touch the zero adjusting screw of the differential transformer since it is factory adjusted.
- Use this valve in combination with a pressure compensation valve. Order a pressure compensation valve separately by referring to the table below as necessary.

| Model No. | Bypass type pressure compensation valve | Reduction type pressure compensation valve |
|--------------|---|--|
| KSP-G02-***C | MRS-02W-**-70 | MGS-02W-**-70 |
| KSP-G02-***A | MRS-02A-**-70 | MGS-02A-**-70 |
| KSP-G02-***B | MRS-02B-**-70 | MGS-02B-**-70 |
| KSP-G03-***C | — | MGS-03W-**-70 |
| KSP-G03-***A | — | MGS-03A-**-70 |
| KSP-G03-***B | — | MGS-03B-**-70 |

- When using the valve in combination with a pressure compensation valve, maintain a pressure difference between port P and the load port within the control range shown in the minimum operating pressure characteristics curve to ensure good pressure compensation performance.
- When using the valve in combination with a bypass type pressure compensation valve, maintain a bypass flow rate of 10 L/min minimum.
- When using the valve in combination with a pressure compensation valve, meter-in control is applied to all flow rate controls.
- When a differential circuit is constructed using this valve, combined use with a pressure compensation valve is not possible.

Refer to Pages J-45 to 48 for the specifications and external dimensions of pressure compensation valves.

Refer to Pages J-86 to 87 for the specifications and external dimensions of the driver (ZDN-2-10).

Contact Details

Before using the product, please check the guide pages at the front of this catalog.

Internet

<https://www.daikinpmc.com/en/>

For latest information, PDF catalogs and operation manuals

Performance curves (viscosity: 32 mm²/s {cSt})

● KSP-G02-2C1*-10-M

Differential pressure - Flow rate characteristics

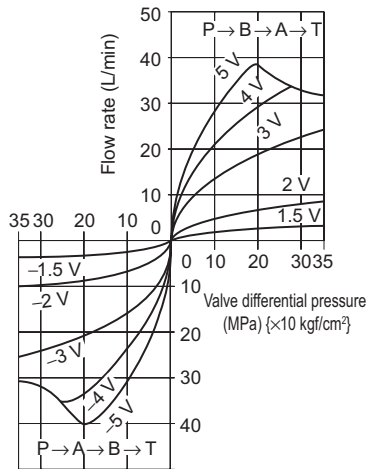

Input voltage - Flow rate characteristics (4-way flow)
ΔP: Valve differential pressure

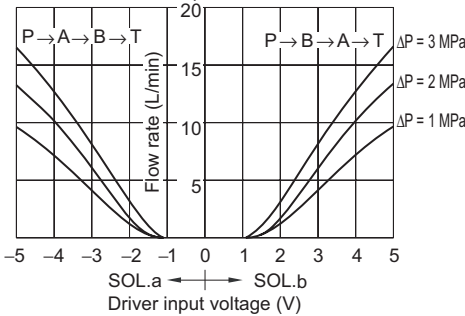

Input voltage - Flow rate characteristics (single side flow)
ΔP: 1 land differential pressure

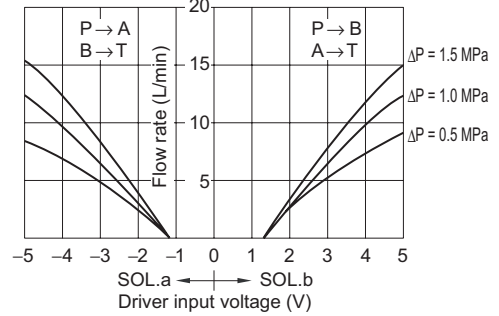

● KSP-G02-2C2*-10-M

Differential pressure - Flow rate characteristics

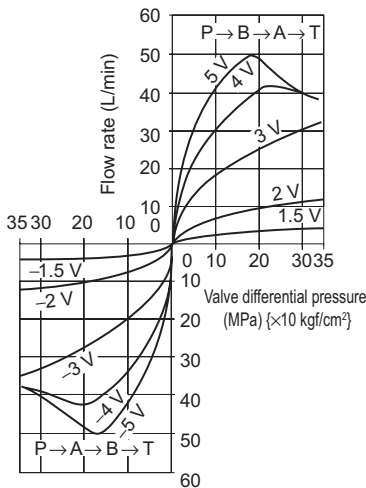

Input voltage - Flow rate characteristics (4-way flow)
ΔP: Valve differential pressure

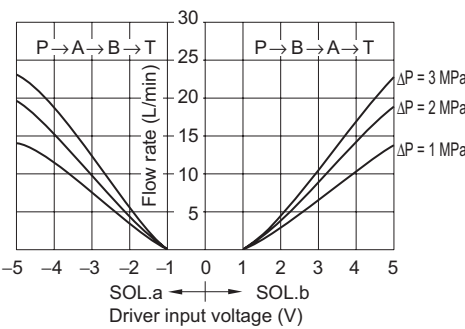

Input voltage - Flow rate characteristics (single side flow)
ΔP: 1 land differential pressure

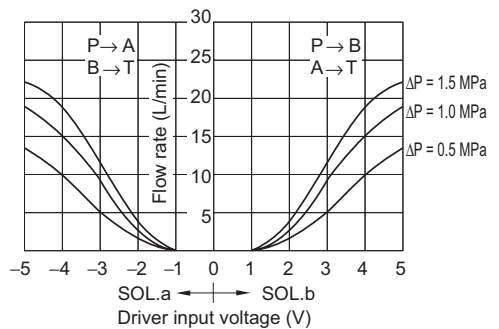

● KSP-G02-2C3*-10-M

Differential pressure - Flow rate characteristics

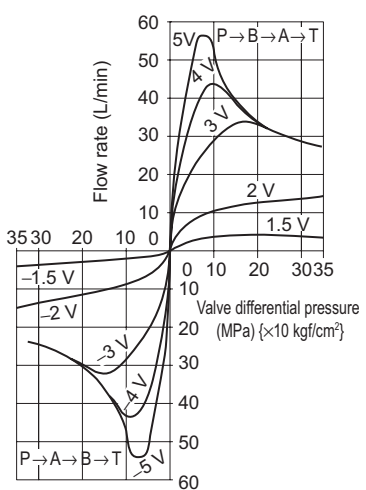

Input voltage - Flow rate characteristics (4-way flow)
ΔP: Valve differential pressure

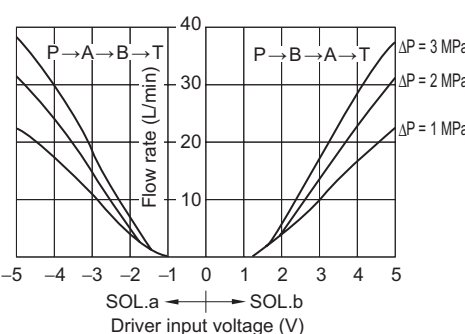

Input voltage - Flow rate characteristics (single side flow)
ΔP: 1 land differential pressure

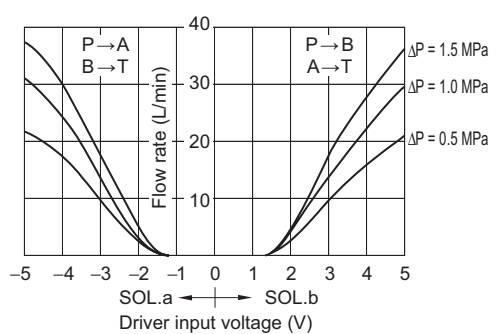

Note: ○ The input voltage - flow rate characteristics are the characteristics when the valve is used in combination with a pressure compensation valve (MRS-02, MGS-02).

○ For the characteristic curves of single solenoid models, see the characteristic curves indicated in the table below.

| Spool type and spool operating method | Performance curve for reference | |
|---------------------------------------|---------------------------------------|----------------|
| | Spool type and spool operating method | Flow direction |
| 2A-H2 | 2C | P → A → B → T |
| 2B-2T | 2C | P → B → A → T |

Performance curves (viscosity: 32 mm²/s {cSt})

● **KSP-G02-44C1×-10-M**

Differential pressure - Flow rate characteristics

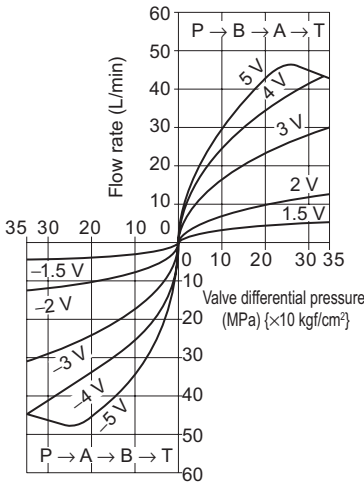

Input voltage - Flow rate characteristics (4-way flow)
ΔP: Valve differential pressure

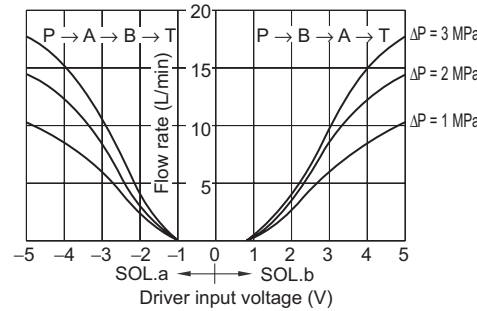

Input voltage - Flow rate characteristics (single side flow)
ΔP: 1 land differential pressure

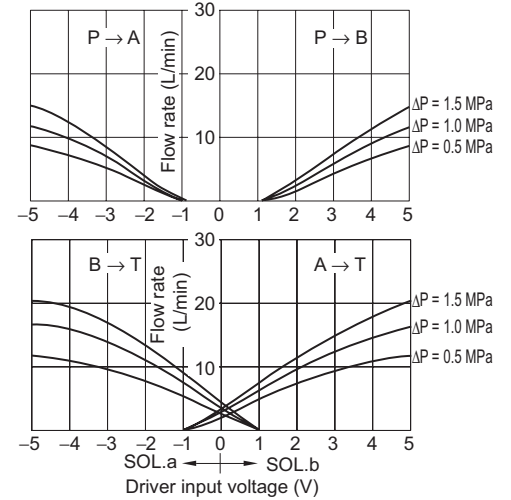

● **KSP-G02-44C2×-10-M**

Differential pressure - Flow rate characteristics

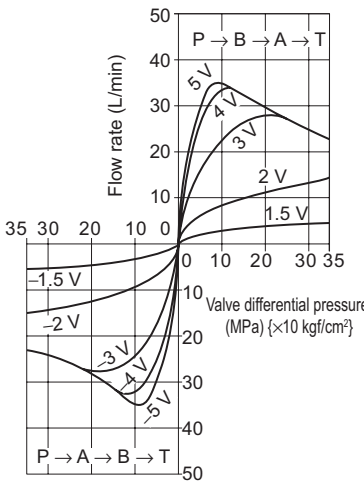

Input voltage - Flow rate characteristics (4-way flow)
ΔP: Valve differential pressure

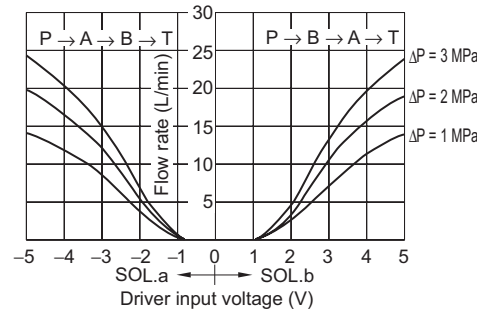

Input voltage - Flow rate characteristics (single side flow)
ΔP: 1 land differential pressure

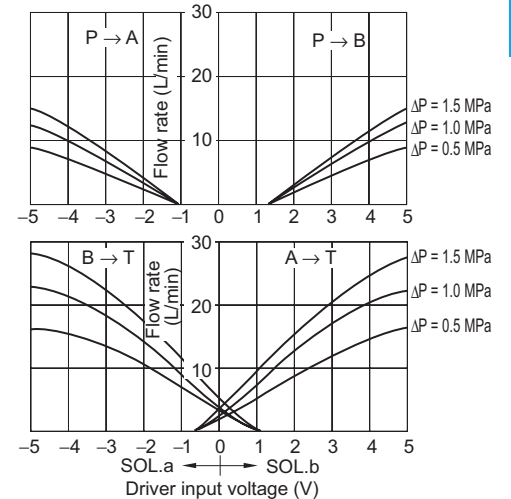

● **KSP-G02-44C3×-10-M**

Differential pressure - Flow rate characteristics

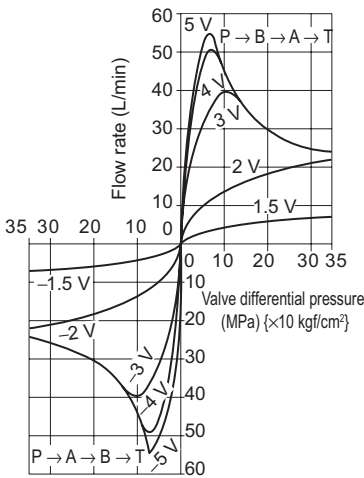

Input voltage - Flow rate characteristics (4-way flow)
ΔP: Valve differential pressure

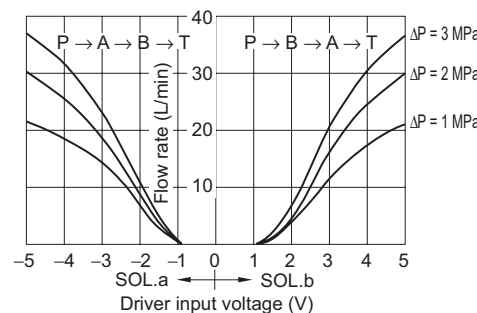

Input voltage - Flow rate characteristics (single side flow)
ΔP: 1 land differential pressure

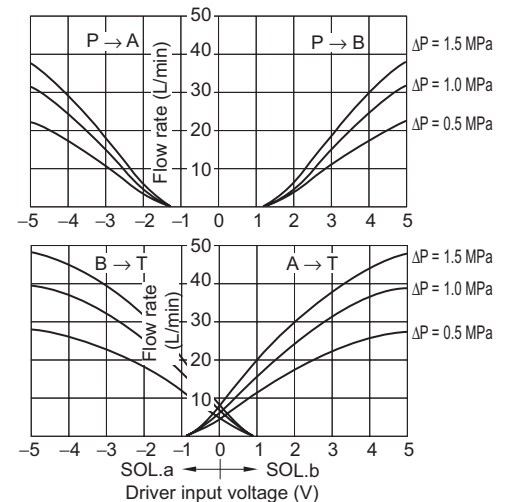

Note: ○ The input voltage - flow rate characteristics are the characteristics when the valve is used in combination with a pressure compensation valve (MRS-02, MGS-02).
○ For the characteristic curves of single solenoid models, see the characteristic curves indicated in the table below.

| Spool type and spool operating method | Performance curve for reference | |
|---------------------------------------|---------------------------------------|----------------|
| | Spool type and spool operating method | Flow direction |
| 81A-H44 | 44C | P → A → B → T |
| 8B-44T | 44C | P → B → A → T |

Performance curves (viscosity: 32 mm²/s {cSt})

● KSP-G02-2C1×-10

Differential pressure -
Flow rate characteristics

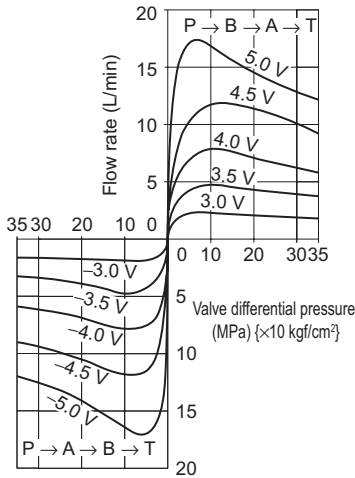

Input voltage -
Flow rate characteristics (4-way flow)
Valve differential pressure ΔP = 1 MPa {10 kgf/cm²}

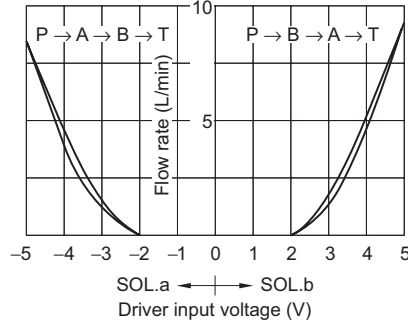

Input voltage -
Flow rate characteristics (single side flow)
1 land differential pressure ΔP = 0.5 MPa {5 kgf/cm²}

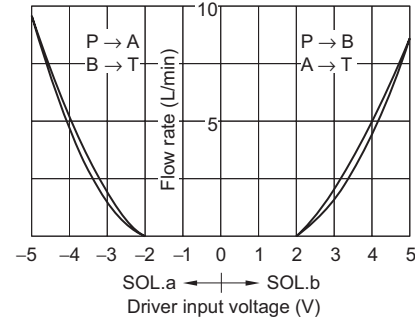

● KSP-G02-2C2×-10

Differential pressure -
Flow rate characteristics

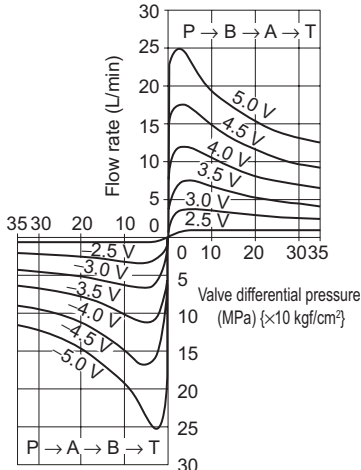

Input voltage -
Flow rate characteristics (4-way flow)
Valve differential pressure ΔP = 1 MPa {10 kgf/cm²}

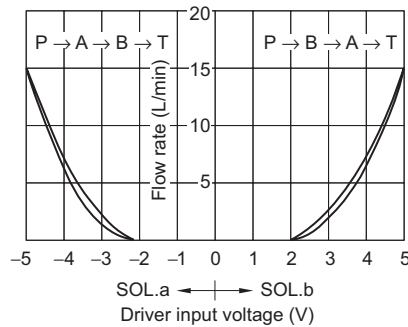

Input voltage -
Flow rate characteristics (single side flow)
1 land differential pressure ΔP = 0.5 MPa {5 kgf/cm²}

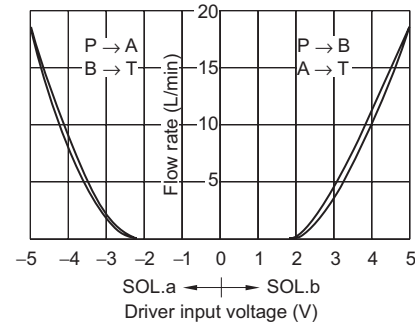

Note: ○ The input voltage - flow rate characteristics are the characteristics when the valve is used in combination with a pressure compensation valve (MRS-02, MGS-02).
○ For the characteristic curves of single solenoid models, see the characteristic curves indicated in the table below.

| Spool type and spool operating method | Performance curve for reference | |
|---------------------------------------|---------------------------------------|----------------|
| | Spool type and spool operating method | Flow direction |
| 2A-H2 | 2C | P → A → B → T |
| 2B-2T | 2C | P → B → A → T |

● KSP-G02-44C1×-10

Differential pressure -
Flow rate characteristics

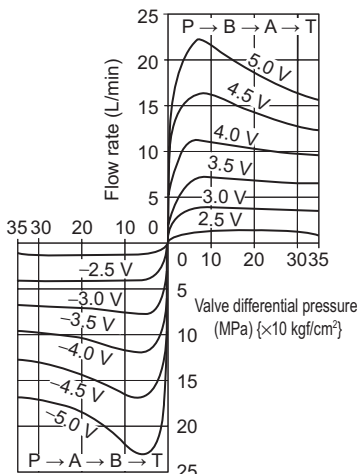

Input voltage -
Flow rate characteristics (4-way flow)
Valve differential pressure ΔP = 1 MPa {10 kgf/cm²}

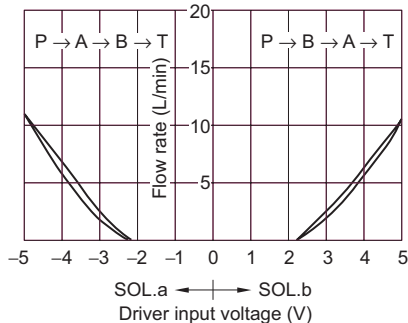

Input voltage -
Flow rate characteristics (single side flow)
1 land differential pressure ΔP = 0.5 MPa {5 kgf/cm²}

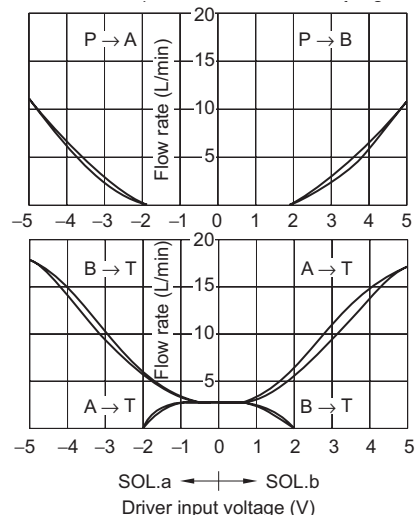

Performance curves (viscosity: 32 mm²/s {cSt})

● KSP-G02-44C2*-10

Differential pressure - Flow rate characteristics

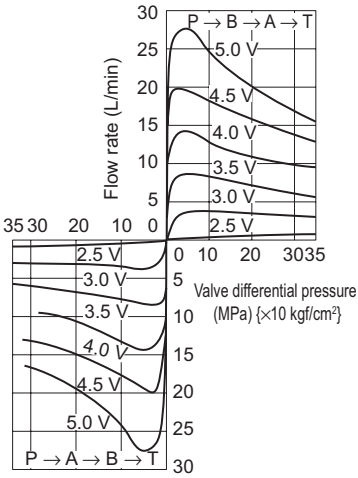

Input voltage - Flow rate characteristics (4-way flow)

Valve differential pressure $\Delta P = 1 \text{ MPa} \{10 \text{ kgf/cm}^2\}$

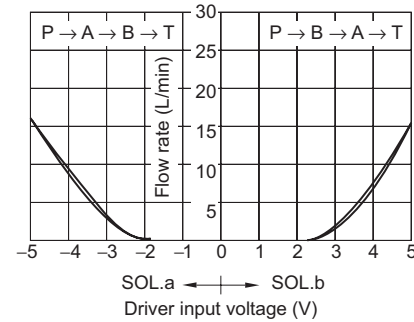

Input voltage - Flow rate characteristics (single side flow)

1 land differential pressure $\Delta P = 0.5 \text{ MPa} \{5 \text{ kgf/cm}^2\}$

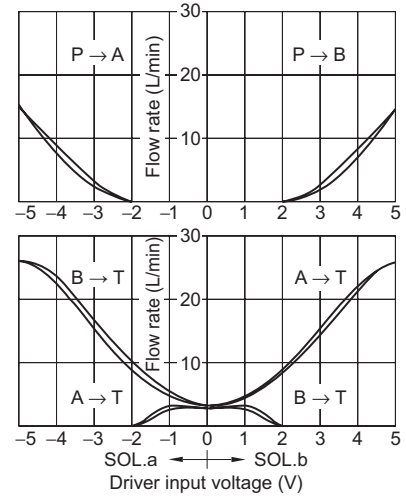

Note: ○ The input voltage - flow rate characteristics are the characteristics when the valve is used in combination with a pressure compensation valve (MRS-02, MGS-02).
○ For the characteristic curves of single solenoid models, see the characteristic curves indicated in the table below.

| Spool type and spool operating method | Performance curve for reference | |
|---------------------------------------|---------------------------------------|----------------|
| | Spool type and spool operating method | Flow direction |
| 81A-H44 | 44C | P → A → B → T |
| 8B-44T | 44C | P → B → A → T |

● KSP-G02-M

Frequency response characteristics

Pressure at port P: 2 MPa {20 kgf/cm²}

Note: Frequency characteristics of the spool displacement voltage in reference to input voltage

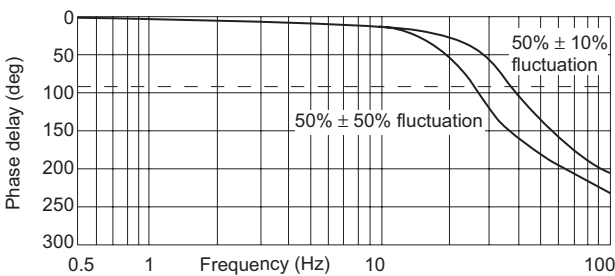
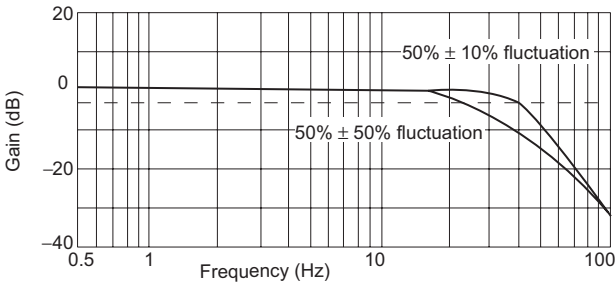

● KSP-G02

Frequency response characteristics

Pressure at port P: 2 MPa {20 kgf/cm²}

Note: Frequency characteristics of the spool displacement voltage in reference to input voltage

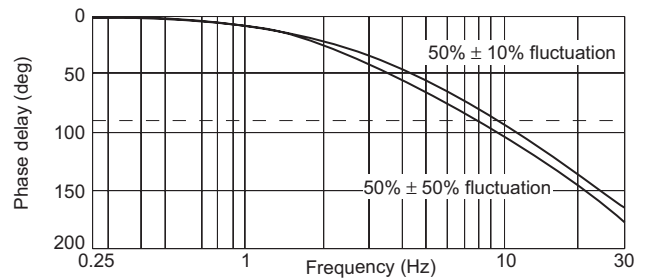
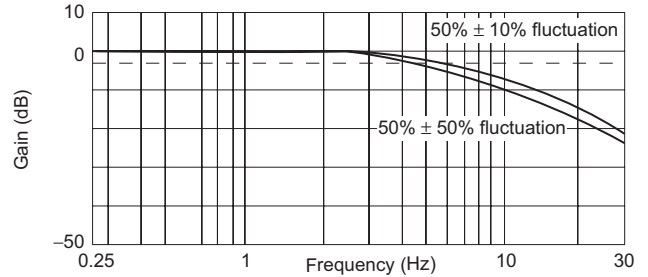

● KSP-G02-M

Step response characteristics

Pressure at port P: 7 MPa {70 kgf/cm²}

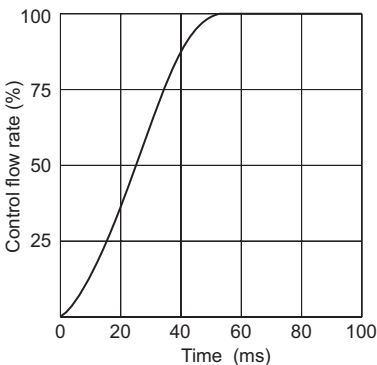

● KSP-G02

Step response characteristics

Pressure at port P: 7 MPa {70 kgf/cm²}

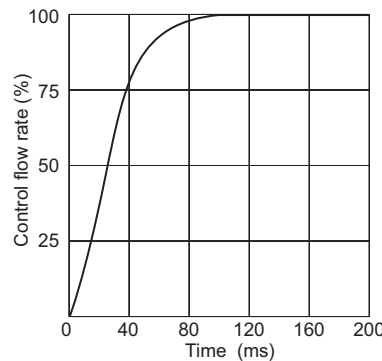

Contact Details

Before using the product, please check the guide pages at the front of this catalog.

Internet

<https://www.daikinpmc.com/en/>

For latest information, PDF catalogs and operation manuals

Performance curves (viscosity: 32 mm²/s {cSt})

● KSP-G03-2C4*-10

Differential pressure -
Flow rate characteristics

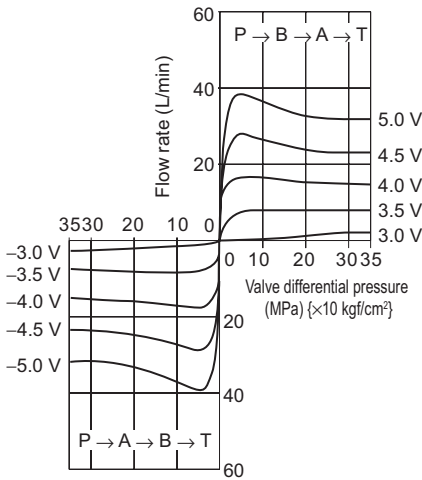

Input voltage -
Flow rate characteristics (4-way flow)
Valve differential pressure $\Delta P = 1 \text{ MPa} \{10 \text{ kgf/cm}^2\}$

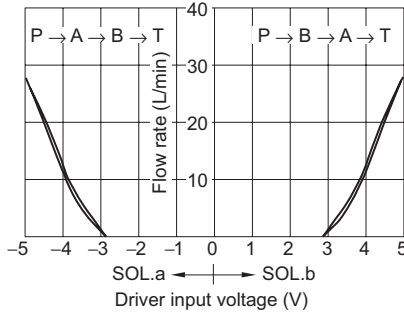

Input voltage -
Flow rate characteristics (single side flow)
1 land differential pressure $\Delta P = 0.5 \text{ MPa} \{5 \text{ kgf/cm}^2\}$

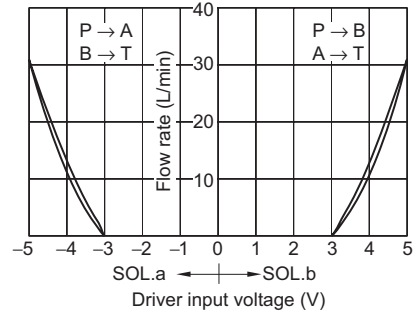

● KSP-G03-2C5*-10

Differential pressure -
Flow rate characteristics

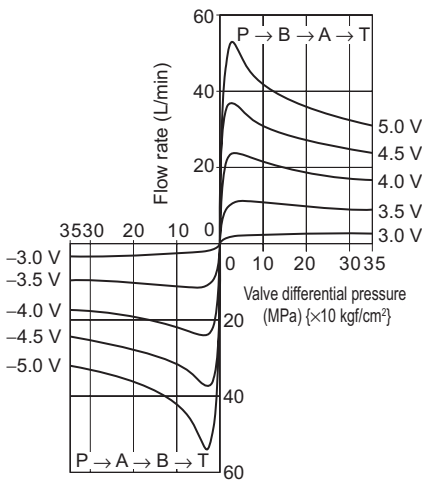

Input voltage -
Flow rate characteristics (4-way flow)
Valve differential pressure $\Delta P = 1 \text{ MPa} \{10 \text{ kgf/cm}^2\}$

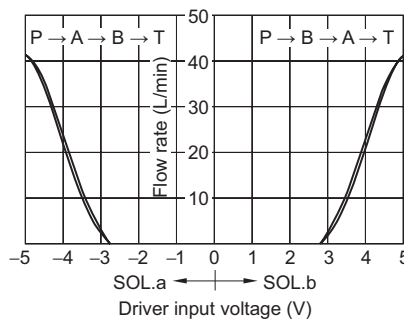

Input voltage -
Flow rate characteristics (single side flow)
1 land differential pressure $\Delta P = 0.5 \text{ MPa} \{5 \text{ kgf/cm}^2\}$

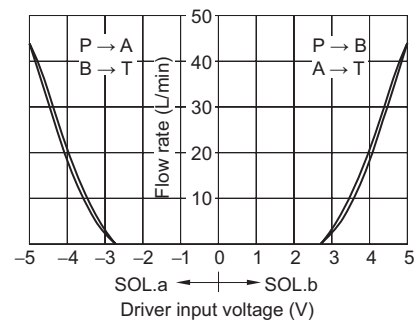

● KSP-G03-44C4*-10

Differential pressure -
Flow rate characteristics

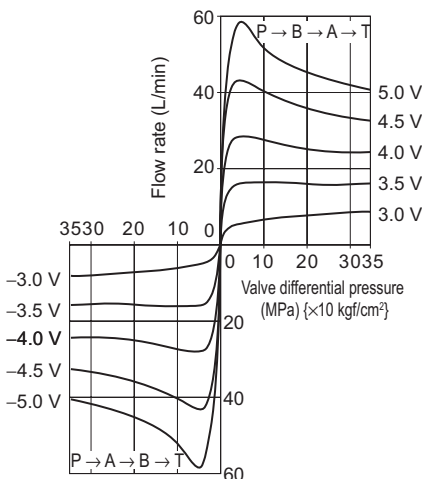

Input voltage -
Flow rate characteristics (4-way flow)
Valve differential pressure $\Delta P = 1 \text{ MPa} \{10 \text{ kgf/cm}^2\}$

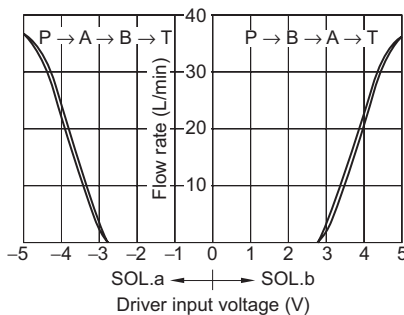

Input voltage -
Flow rate characteristics (single side flow)
1 land differential pressure $\Delta P = 0.5 \text{ MPa} \{5 \text{ kgf/cm}^2\}$

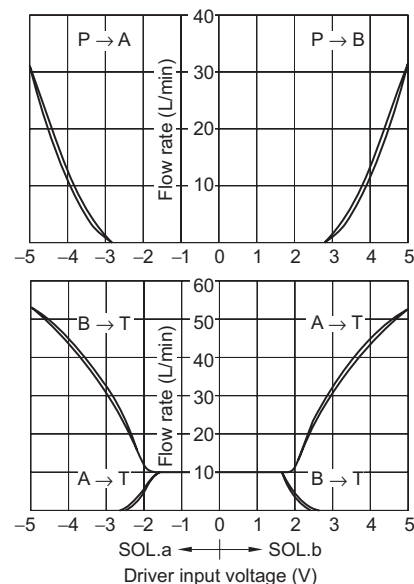

Contact Details

Before using the product, please check the guide pages at the front of this catalog.

Internet

<https://www.daikinpmc.com/en/>

For latest information, PDF catalogs and operation manuals

Performance curves (viscosity: 32 mm²/s {cSt})

● KSP-G03-44C5*-10

Differential pressure
- Flow rate characteristics

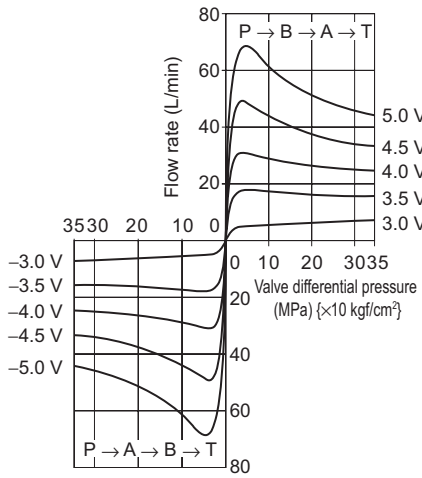

Input voltage
- Flow rate characteristics (4-way flow)
Valve differential pressure $\Delta P = 1 \text{ MPa} \{10 \text{ kgf/cm}^2\}$

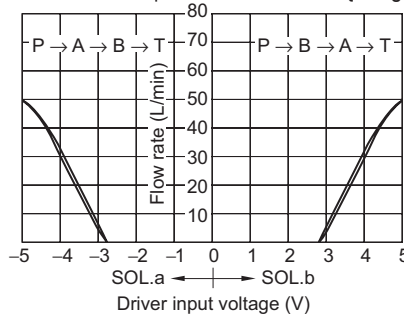

Input voltage -
Flow rate characteristics (single side flow)
1 land differential pressure $\Delta P = 0.5 \text{ MPa} \{5 \text{ kgf/cm}^2\}$

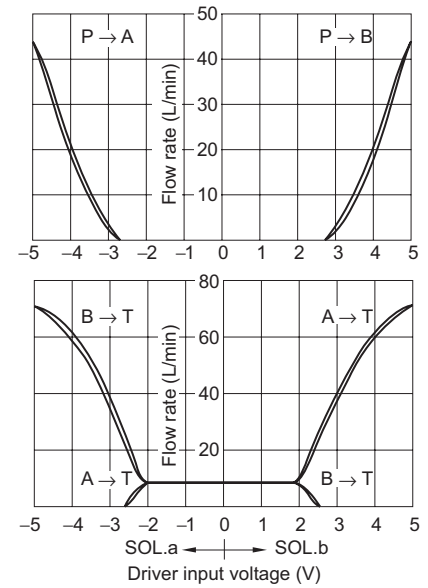

Note: ○ The input voltage - flow rate characteristics are the characteristics when the valve is used in combination with a pressure compensation valve (MGS-03).
○ For the characteristic curves of single solenoid models, see the characteristic curves indicated in the table below.

| Spool type and spool operating method | Performance curve for reference | | Spool type and spool operating method | Performance curve for reference | |
|---------------------------------------|---------------------------------------|----------------|---------------------------------------|---------------------------------------|----------------|
| | Spool type and spool operating method | Flow direction | | Spool type and spool operating method | Flow direction |
| 2A-H2 | 2C | P → A → B → T | 81A-H44 | 44C | P → A → B → T |
| 2B-2T | 2C | P → B → A → T | 8B-44T | 44C | P → B → A → T |

● KSP-G03

Frequency response characteristics

Pressure at port P: 7 MPa {70 kgf/cm²}

Note: Frequency characteristics of the spool displacement voltage in reference to input voltage

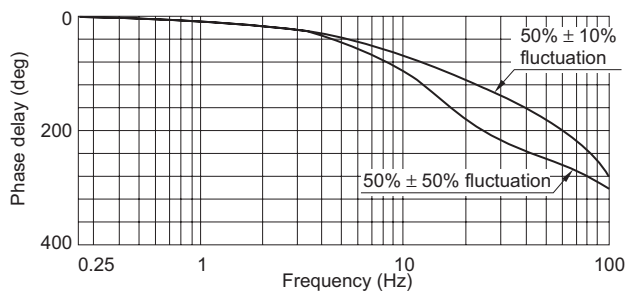
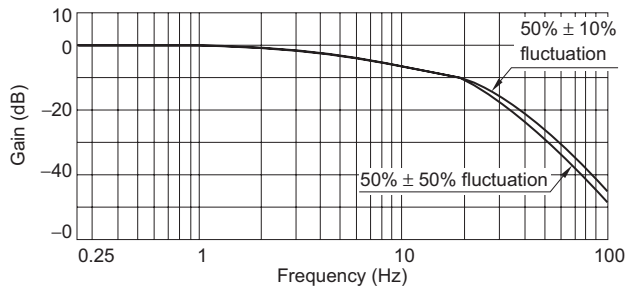

Step response characteristics

Pressure at port P: 7 MPa {70 kgf/cm²}

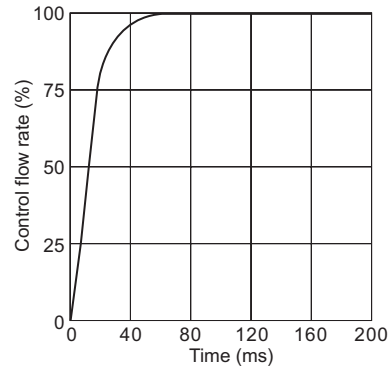

Contact Details

Before using the product, please check the guide pages at the front of this catalog.

Internet

<https://www.daikinpmc.com/en/>

For latest information, PDF catalogs and operation manuals

External dimension diagram

KSP-G02-※※C※※-10

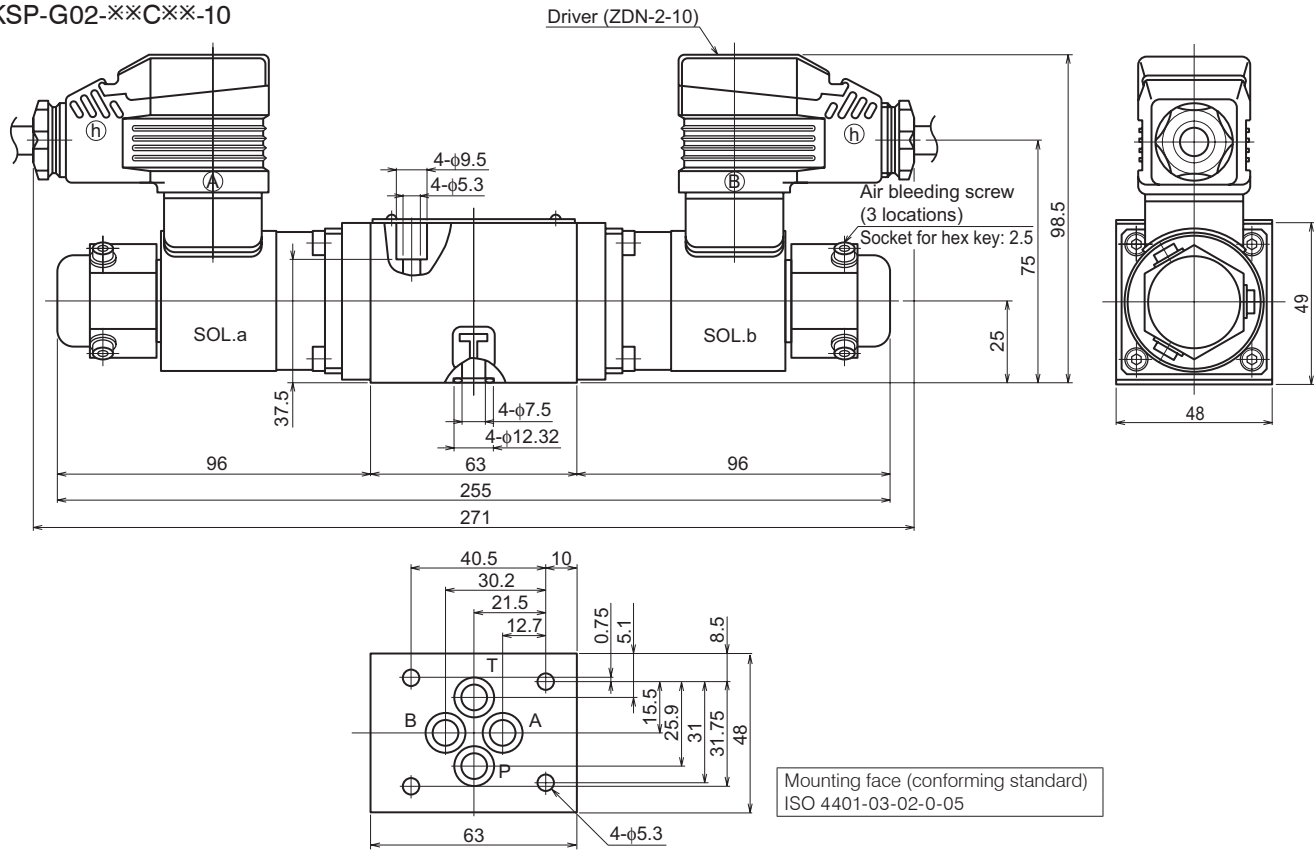

KSP-G02-※※A※※-10

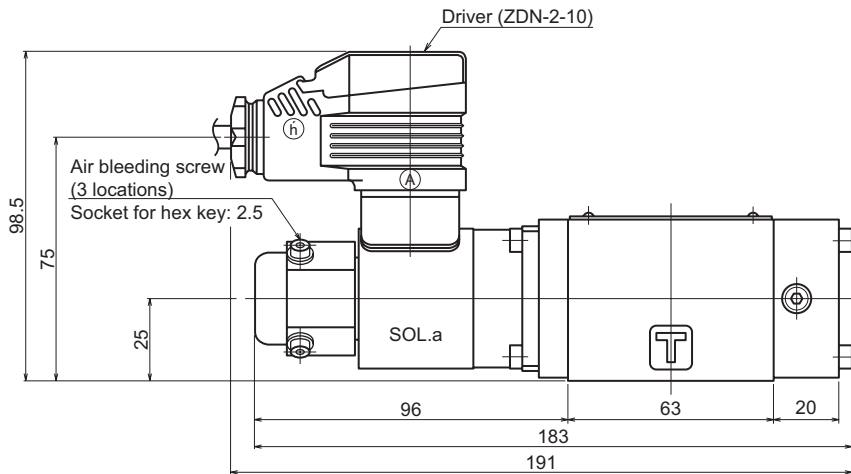

KSP-G02-※※B※※-10

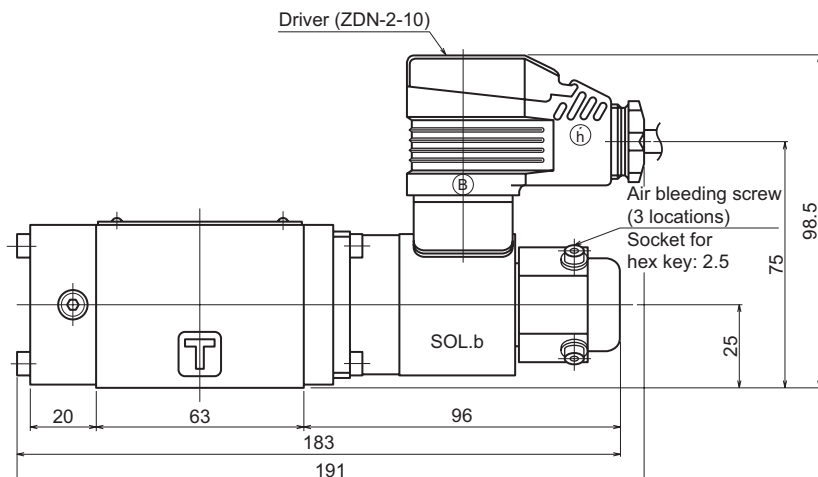

Contact Details

Before using the product, please check the guide pages at the front of this catalog.

Internet

<https://www.daikinpmc.com/en/>

For latest information, PDF catalogs and operation manuals

External dimension diagram

KSP-G02-**C**-10-N

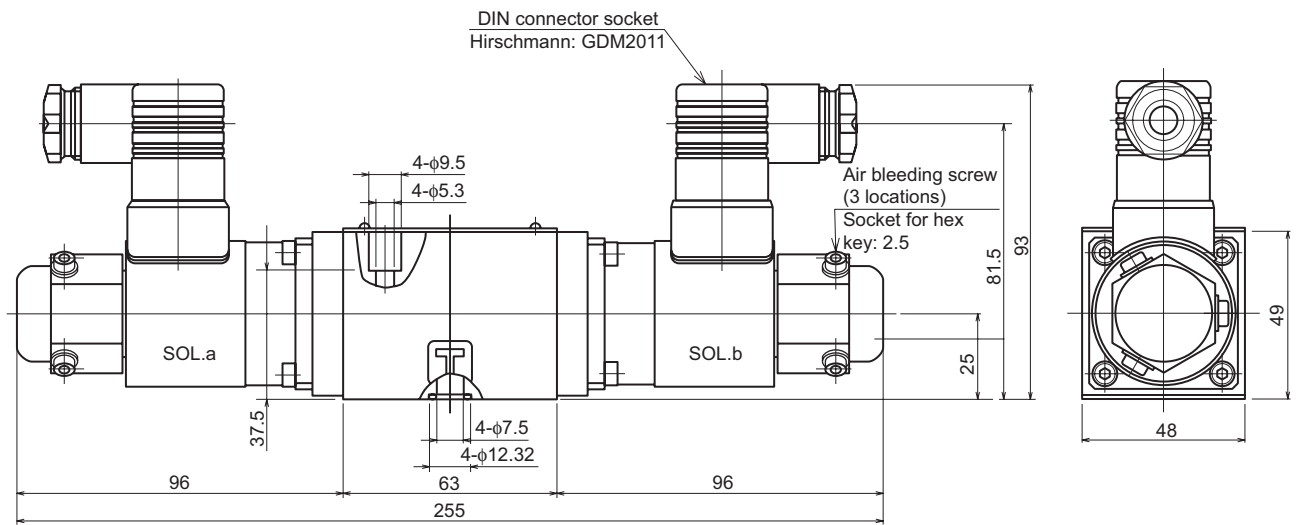

KSP-G02-**A**-10-N

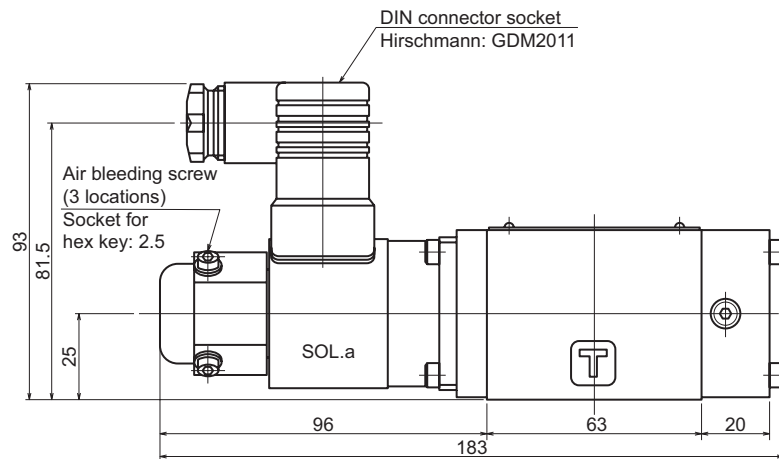

KSP-G02-**B**-10-N

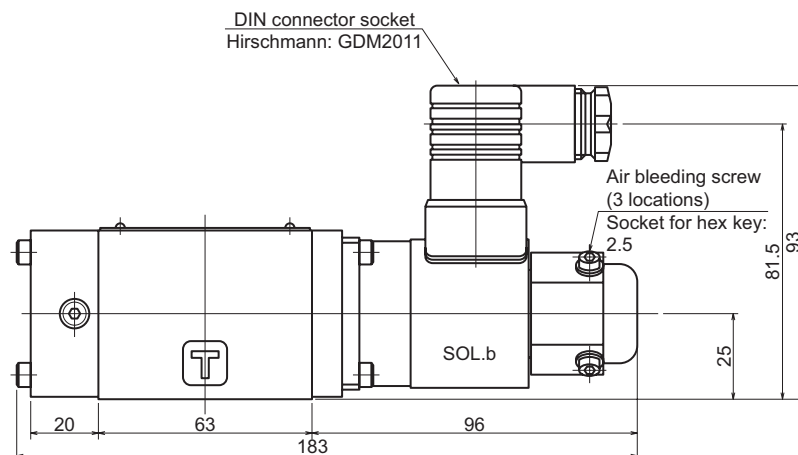

Contact Details

Before using the product, please check the guide pages at the front of this catalog.

Internet

<https://www.daikinpmc.com/en/>

For latest information, PDF catalogs and operation manuals

External dimension diagram

KSP-G03-**C**-10

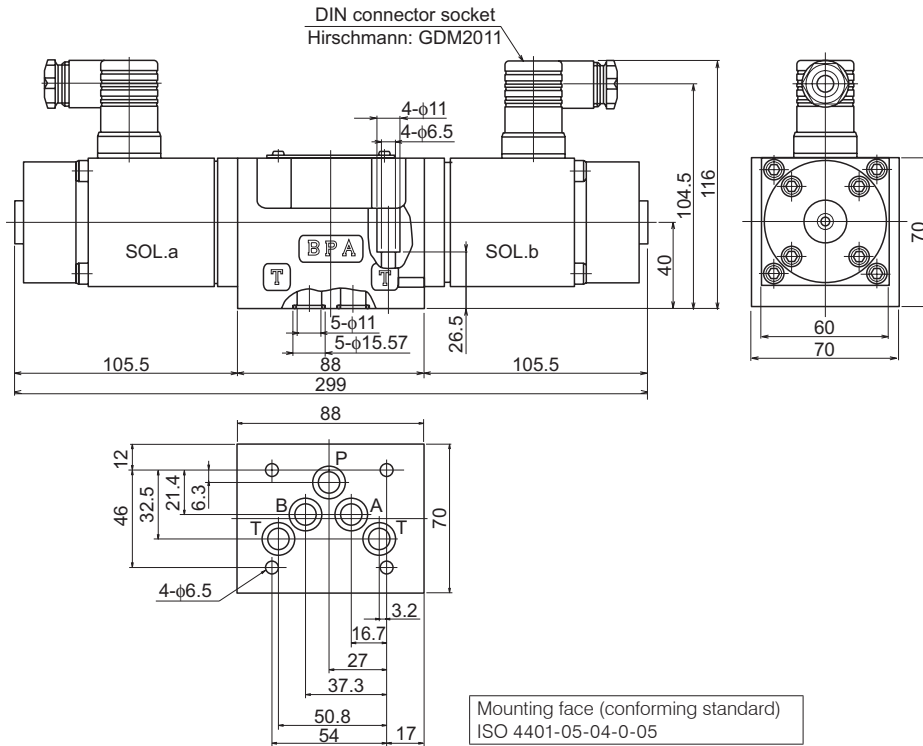

KSP-G03-**A**-10

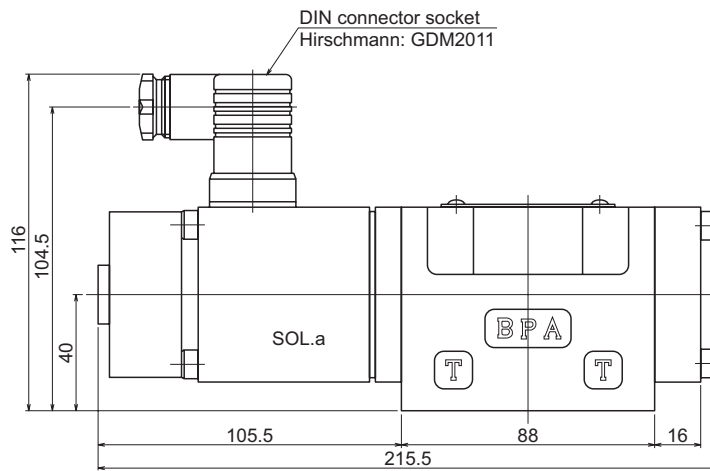

KSP-G03-**B**-10

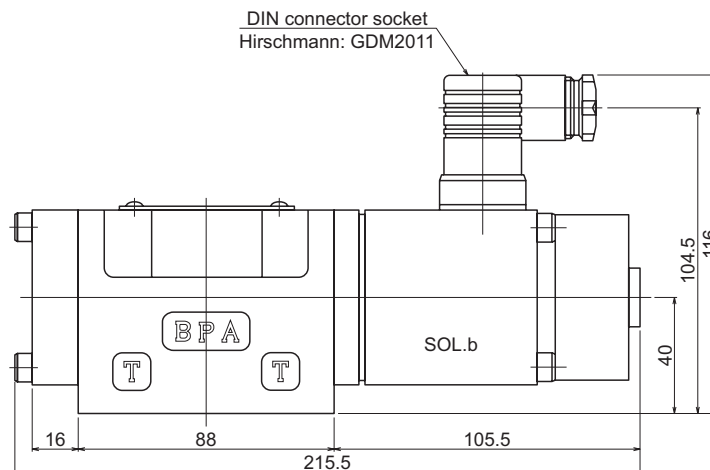

Contact Details

Before using the product, please check the guide pages at the front of this catalog.

Internet

<https://www.daikinpmc.com/en/>

For latest information, PDF catalogs and operation manuals

Sectional structural diagram

KSP-G02-※C※-10-M

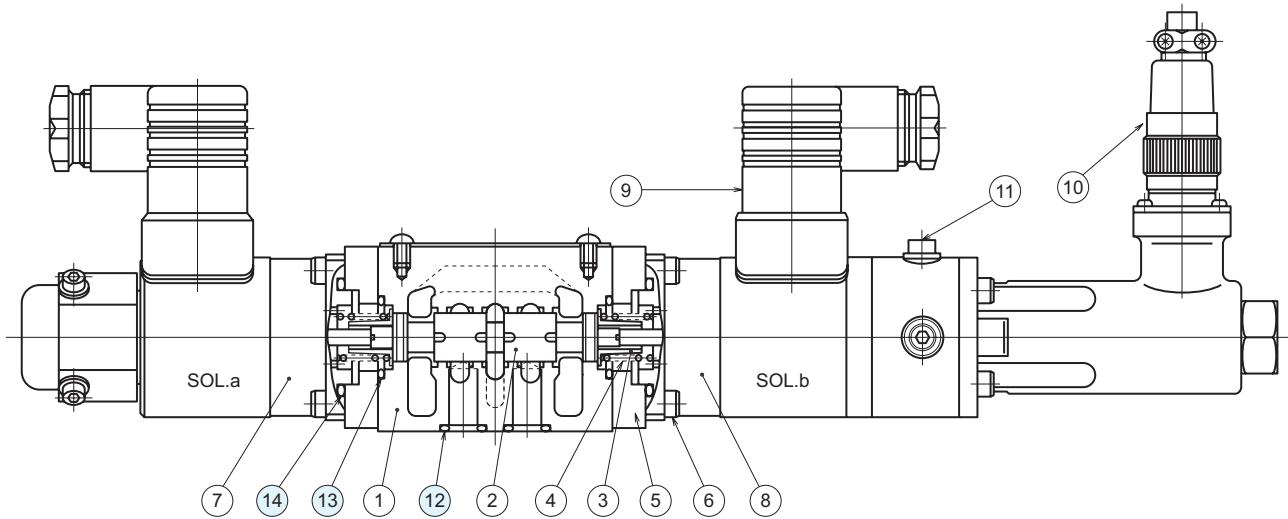

Sealing part table

| Part No. | Name | Quantity | | Part specifications |
|----------|--------|----------|----------|-----------------------|
| | | Type C | Type A/B | |
| 12 | O-ring | 4 | 4 | AS568-012 (NBR, Hs90) |
| 13 | O-ring | 2 | 2 | JIS B 2401 1B P18 |
| 14 | O-ring | 2 | 1 | AS568-121 (NBR, Hs90) |

KSP-G03-※C※-10

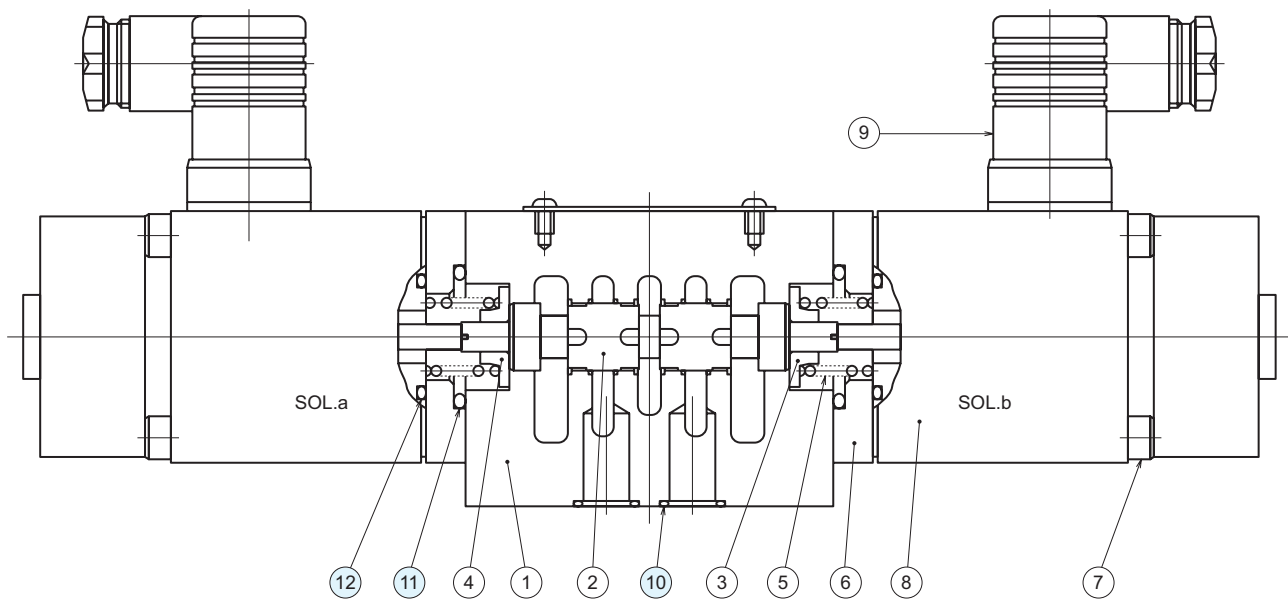

Sealing part table

| Part No. | Name | Quantity | | Part specifications |
|----------|--------|----------|----------|-----------------------|
| | | Type C | Type A/B | |
| 10 | O-ring | 5 | 5 | AS568-014 (NBR, Hs90) |
| 11 | O-ring | 2 | 2 | JIS B 2401 1B P28 |
| 12 | O-ring | 2 | 1 | AS568-120 (NBR, Hs90) |